

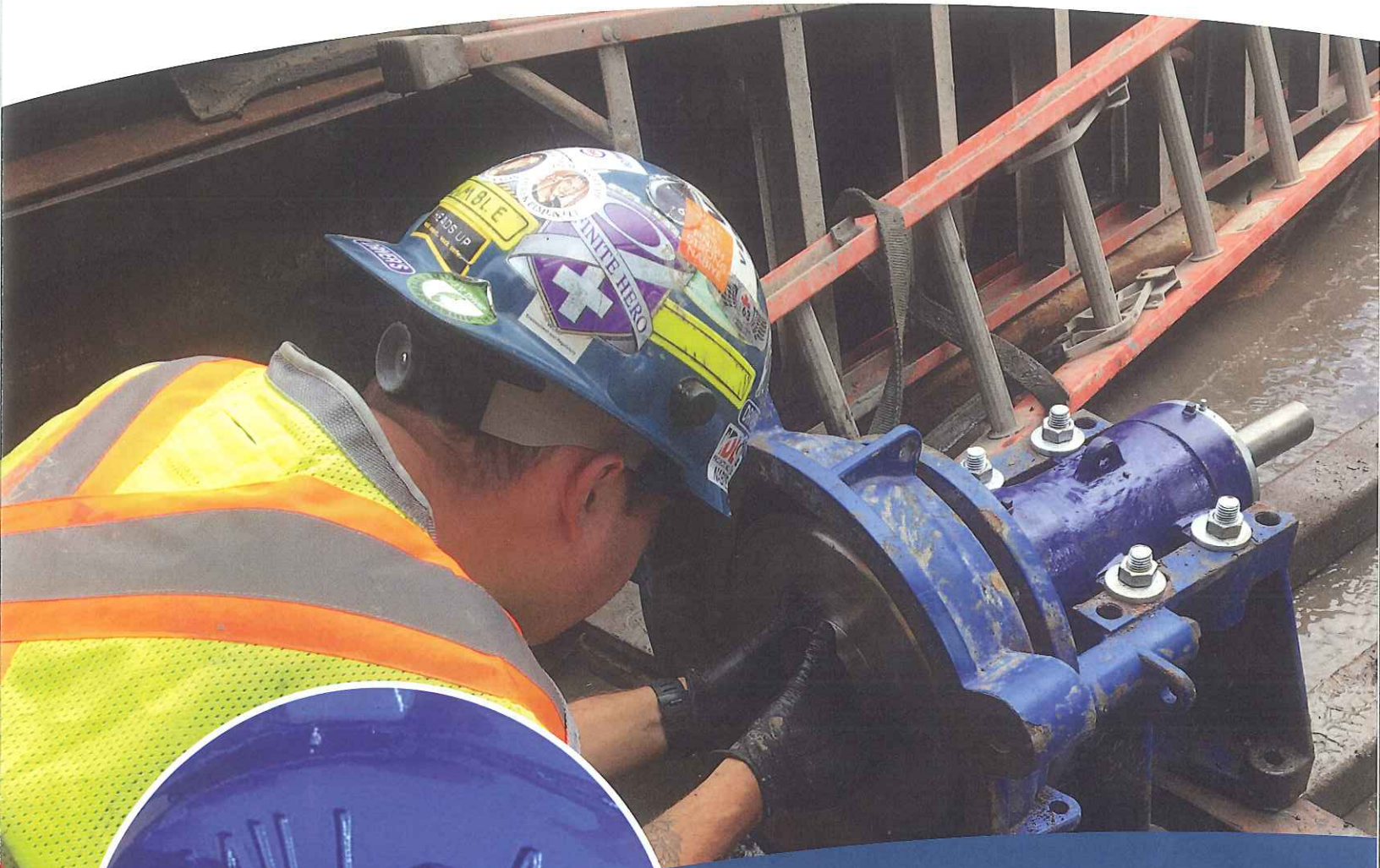

ICS
WEAR GROUP INC

**PREPARING YOU FOR
THE SLURRY AHEAD**



ICS MILL MASTER

The Heavy Duty ICS Mill Master Pump line provides you the opportunity to build your pump – a pump specifically designed to meet your site specific application.



The ICS Mill Master design includes:

Bearing Assembly Unit (BAU) – Newly designed and industry proven to prevent contamination from entering;

- contaminant free
- leak free
- hassle free
- 100% interchangeable with older models

Liners – Metal, Rubber and Polyurethane liners are completely interchangeable. Liners come complete with o-rings and seals to ensure change outs are minimized and uptimes are maximized.

Cover/Frame Plate – 2 piece design enables effective and efficient maintenance with the cast lifting lugs. Designed for both standard and high pressure applications.

Impeller – Metal impellers are balanced and cast in 28,30,32,34,36% HCWI; rubber and metal impellers are interchangeable. Ask about reduced eye, high efficiency and vane modified impellers.

Throatbush – Metal, rubber or polyurethane throatbushes are completely interchangeable. Metal cast in 28 to 36% high chrome with tapered ends.

Frame – Mill Master Heavy Duty cast design ensures there is no vibration. Move your impeller without having to fully disassemble your pump with the exterior adjusting bolt.

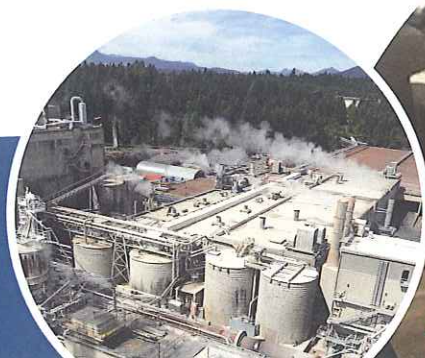

250-722-0169
info@icsweargroup.com

ICS Mill Master Pumps provide 100% interchangeability

The Heavy Duty ICS Mill Master Pump Line is custom fit depending on the availability of gland water with stuffing boxes, expeller / expeller rings, or mechanical seals.

ICS Mill Master sleeves can be supplied in a wide range of materials. Tapered grooves on both ends of the sleeves protects the o-ring from excessive wear and corrosive contaminant.

Stuffing Boxes and Expeller / Expeller Rings are investment cast up to the 8 x 6 Size.

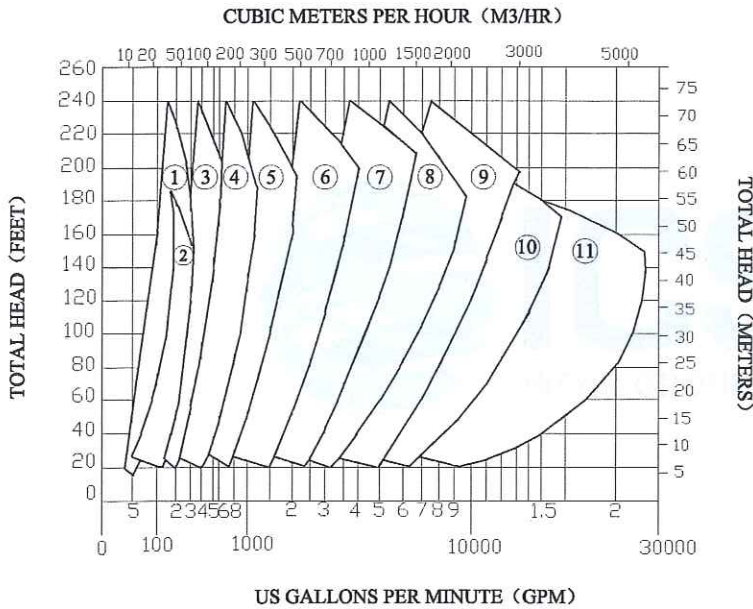
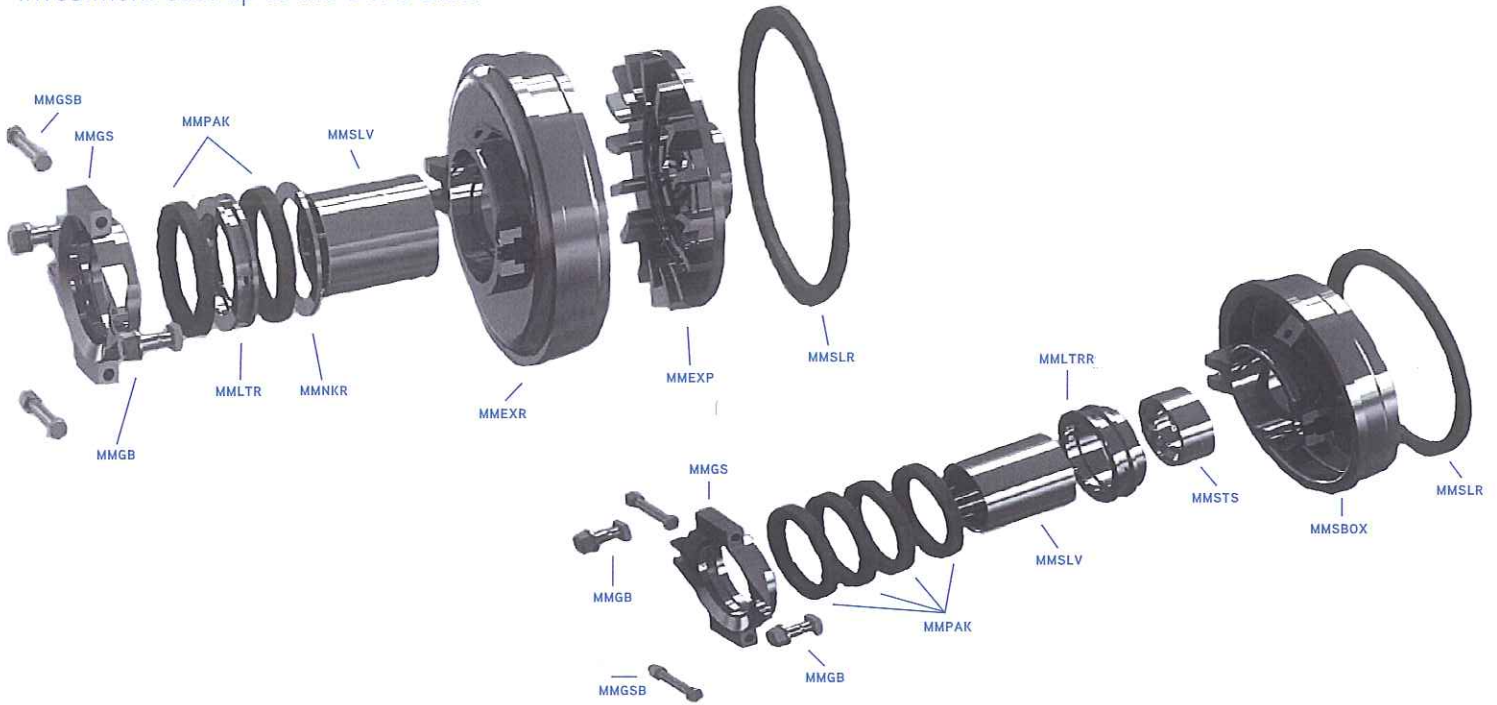

1	ICSHDMM151
2	ICSHDMM215
3	ICSHDMM32
4	ICSHDMM43
5	ICSHDMM64
6	ICSHDMM86
7	ICSHDMM108
8	ICSHDMM1210
9	ICSHDMM1412
10	ICSHDMM1614
11	ICSHDMM2018



ICS Wear Group is a Canadian Manufacturing Company

Based in British Columbia Canada. By using the latest CAD CAM techniques and safest manufacturing principles, ICS is able to keep the costs down and delivery times within required dates. Ask about our free stocking service.

Meeting International Standards of ISO 9001:2015 ICS Wear Group works hard every day to maintain this standard. Safety is Key at all ICS Wear Group facilities from the office to the warehouse, everyone looks out for each other by completing job hazard assessments' every day. Our newest location in Nanaimo BC, just surpassed 2000 hrs LTI Free.

The ICS Mill Master Line of Pumps are not our only product line. ICS Wear Group's foundry operations can cast all of your mill liner needs with average savings of 30% compared to that of the OEM's. We can supply all your chute liners, skirt board liners, wear liners, loaf liners, shell liners and feeder pans. Liners can be cast in a wide range of alloys including chrome molly, high chrome white iron and proprietary resistant metals. In need of a quick fix contact us today about our ICS-200 quick drying wear epoxy.

Between the ICS warehouses we have over 8 million dollars in spare parts stocked allowing for quick delivery which equals less downtime for you.



The ICS team provides quotes within 24hours and our pricing is fixed for 12 months, we offer site and office visits. The visits allow us to meet our customers face to face and discuss further solutions and business opportunities.